



Fireray[®] 5000

Motorized Reflective Optical Beam Smoke Detector

The Fireray[®] 5000 System is an auto-aligning, self-correcting infrared reflective Beam Smoke Detector. Up to 2 Detector heads can report to a single ground level controller. In addition, each system controller houses two pairs of fire and trouble relays, one per Detector. Once the Detector head is installed, using the easy fit mounting system, an integral LASER can be activated. This allows the reflective Prism to be located quickly with confidence.

The Auto-Align function ensures proper alignment and maximum signal during the Beam installation. Building Movement Tracking[™] automatically steers and maintains the Beam in the optimum position for reliable performance. The signal generated in the Transmitter element and reflected by the Prism back to the Receiver element is analyzed for the presence of smoke. The internal microprocessor determines an alarm condition when a predetermined level obscuration is reached.

The system is designed to be mounted so the Beam will project between 19" (0.5m) and 24" (0.6m) below the ceiling. Lateral detection may be up to 30ft. (9.144m) on either side of the Beam, providing a maximum total coverage area of up to 19,800 square feet (60ft. x 330ft. or 18.29m x 100m). For installations complying with UL268/NFPA72, the maximum distance of Detector and Reflector from the ceiling must be 10% of the distance between floor and ceiling.

Engineering Specification

The projected Beam type Smoke Detector shall be listed to U.L. 268 and shall consist of up to two integrated Transmitter, Receiver Detector heads and single Low-Level remote control unit. The Detector shall operate between a range of 26.2 ft to 328 ft (8 m to 100 m). The temperature range of the system shall be -4°F to 131°F (-20°C to 55°C). The Beam Detector heads shall include an integral built-in laser pointer to assist Prism mounting. The Beam Detector shall feature Automatic Gain Control which will compensate for gradual signal deterioration from dirt accumulation on the lenses and Prisms.

The Beams Detector heads shall include Building Movement Tracking[™] self-correcting motorized head feature to ensure the unit is always receiving maximum signal available, and shall automatically compensate for building shift. The unit shall include a Low-Level remote display and control unit with LCD read-out for set-up, reporting and testing of up to 2 separate Detector heads. The system shall have separate Trouble and Alarm relays for each of the 2 channels.



Features

- Up to 2 Detector Heads reporting to one Low-Level Controller
- Range of 26.2 ft to 328 ft (8 m to 100 m)
- Long Range Prism kit extends range from 160ft (50m) to 330ft (100m)
- Built in Laser assisted Prism mounting
- Auto-Alignment 2 to 4 minutes per head
- Building Movement Tracking[™]: Auto-Correction due to building shift
- Built-in electronic UL/ULC/FM obscuration-acceptance fire test
- Contamination compensation
- Separate Trouble and Alarm relays for each of the 2 channels
- Password protected settings
- Low current draw 5 to 8.5mA
- Built-in 1/2"/M-20 conduit knock-outs on the system Controller
- Programmable alarm thresholds: 10% - 60% in 1% increments
- Programmable Fault and Alarm delay: 2-30 Seconds

The system shall be capable of programming alarm thresholds of 10% to 60% in 1% increments. The system shall be capable of programming delay to fault and delay to alarm from 2 seconds to 30 seconds in 1 second increments. Test and acceptance of the system shall be carried out by using the UL/ULC/FM approved internal electronic obscuration fire test. The projected Beam type Smoke Detector shall be a 4-wire 24 VDC device to be used with a separately supplied 4-wire control panel.



Fireray 5000 Accessories

Construction Specification

Housing:	Flame Retardant PC UL94 V0
IP Rating:	IP54
Finish:	Light Grey/Black
Weight:	Head & Controller 3.24 lbs (1.47 kg)
Dimensions:	Head: 5.28" H x 5.16" L x 5.28" W (134mm H x 131mm L x 134mm W) Controller: 3.43" H x 9.06" L x 7.95" W (87mm H x 230mm L x 202mm W) Prism: 0.37" H x 4.13" L x 3.94" W (9.5mm H x 105mm L x 100mm W)

Electrical Specification

Primary Input Power:	14 to 36 VDC
Standby Current:	Low Current Mode: 5mA to 8.5mA @ 24VDC depending on number of detector heads used High Current Mode: 37mA @ 24VDC
Alarm Current: -	5mA to 8.5mA @ 24VDC depending on number of detector heads used
Relay Contacts:	1A @ 30VDC Resistive
Reset Time:	5 Seconds maximum
Start Up Time:	45 Seconds
Optical Wavelength:	850nm
Alarm Threshold:	10% - 60% (35% Default)
Temperature Rating:	-4°F to 131°F (-20°C to 55°C) For UL Listed Installations: 32°F to 100°F (0°C to 38°C)
Relative Humidity:	0% to 93% RH non-condensing
Range:	26.2 ft to 328 ft (8 m to 100 m)
Cabling Between each Detector & Controller:	18-14 AWG 1-Pair

Specifications and wiring information are provided for information only and are believed to be accurate. FFE Ltd assumes no responsibility for their use. Data and design are subject to change without notice. Installation and wiring instructions are shipped with the products and should always be used for actual installation. For more information, contact your Sales Representative.



US Sales and Distribution

FFE Limited
1455 Jamike Ave Ste 200
Erlanger, KY 41018-3147 USA

t +1 859 957 1570

e america@ffeus.com
w www.ffeus.com

Listings

- UL - S3417
- ULC - S3417
- MEA - 22-08-E
- CSFM - 7260-1508-104
- FM Approved
- Maryland - 2243

Dimensions

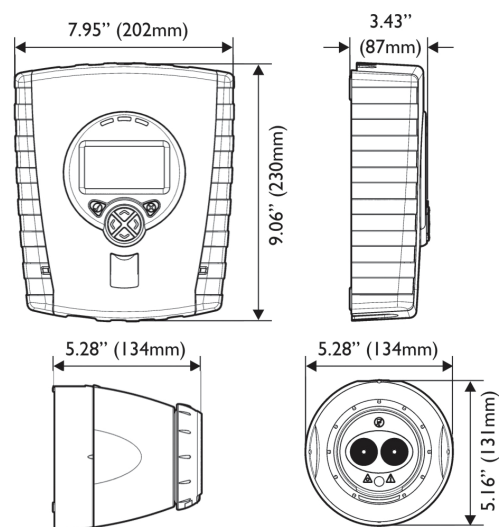

Ordering Information

- 5000-103 Reflective Auto Align Beam Smoke Detector 26.2ft. to 330ft. (8m to 100m). System includes 1 Detector Head, 1 Controller and 1 Prism (103) or 4 Prisms (104).
- 5000-031 Additional Detector Head and 1 Prisms - Use up to one additional Head per 5000-103 or 5000-104
- 5000-005 Universal Alignment Bracket - Used with F-5000 Detector Head, 5000-007 and 5000-008
- 1170-000 Universal I30 Alignment Bracket - Used with F-5000 Detector Head, 5000-007 and 5000-008
- 5000-003 System Controller
- 1030-000 Reflector Wall Bracket (white in color)
- 1031-000 Reflector Wall Bracket (black in color)
- 5000-007 4 Prism Alignment Adaptor Plate
- 5000-008 1 Prism Alignment Adaptor Plate
- 5000-009 Controller Back Box
- 5000-010 Semi-Flush Trim Plate for 5000-009
- 5000-011 Detector Surface Mount Uni-Box
- 5000-012 Detector 2 gang Mounting Plate
- 5000-014 Ceiling Pendant Mount Bracket
- 1000-018 Wire Protective Cage for Detector
- 1000-019 Wire Protective Cage for Controller
- 23901.01 Replacement Prism