



1080-000

Fireray 3000 Anti-Condensation Heater

The Fireray® 3000 Anti-Condensation Heater has been designed to be used in environmental conditions where condensation affects the operation of optical beam smoke detectors.

Condensation occurs when the surrounding air is at a higher temperature than the surface that it comes in contact with. As air contains water, in the form of vapor, this will deposit on the cooler surface thus forming condensation.

The design of the Fireray® 3000 Anti-Condensation Heater utilizes forced air which results in a circulating current of warm air maintaining the detector lens at an incrementally higher temperature than the surrounding air. The heater will reduce the likelihood of condensation forming on the lens which, in turn, reduces the potential for false alarms.

Features

- Bespoke bracket to ensure optimum performance of heater
- Designed to prevent the build-up of condensation
- For use in temperature controlled storage areas and cold environments
- Order heater separately for transmitter and receiver

Technical Specification

Operating voltage:	24 V AC/DC
Power consumption at 24V:	20 W
Maximum in-rush current:	3 A
Steady-state current at 24V:	0.8 A (Typical)
Operating temperature:	14°F to 113°F
Recommended fuse rating:	T2A
Connections:	4 leads (2 for heater & 2 for fan)
Average temperature increase of lens above ambient:	50°F
Weight:	9.7oz



Anti-Condensation Heater Bracket



Anti-Condensation Heater with Transmitter

Anti-Condensation Heater with Receiver and Universal Bracket

Dimensions

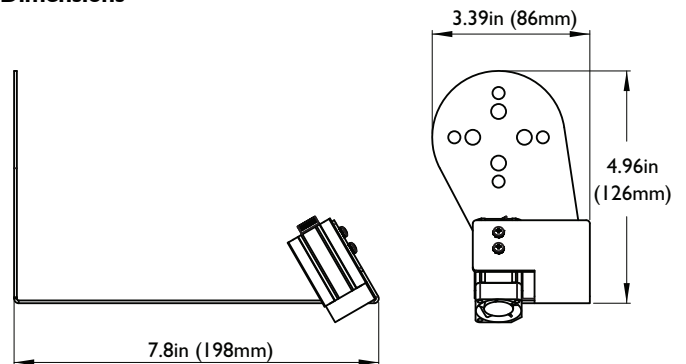

Single heater unit ordering code: 1080-000

Product code formerly known as: 3000-204

Specifications and wiring information are provided for information only and are believed to be accurate. FFE Ltd assumes no responsibility for their use. Data and design are subject to change without notice. Installation and wiring instructions are shipped with the products and should always be used for actual installation. For more information, contact your Sales Representative.

Document Part No: 24-0206-02



FFE Limited
1455 Jamike Ave Ste 200, Erlanger
KY 41018-3147 USA

t +(859) 957-1570
e america@ffeus.com
w www.ffeus.com

www.ffeus.com