

Weatherproof Vibration Switch Types 3171MR and 3171S

Installation and Operating Manual

EN

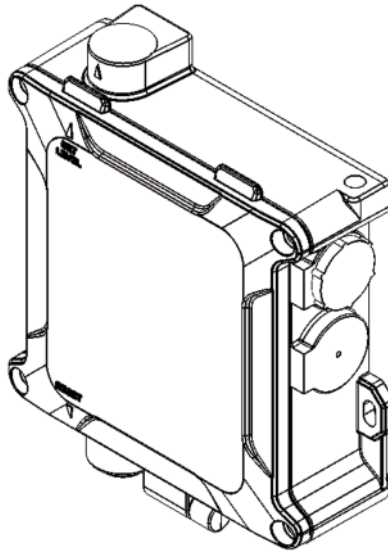

1. Introduction

The type 3171 is a low-cost, vibration-sensitive, safety switch for the protection of rotating and reciprocating machinery. It is adjusted to operate above the machine's normal running levels of vibration, activating machine shut-down circuits and/or alarms and to switch off the machine before catastrophic failure.

The switch detects vibration in all directions. Unbalanced forces created by failing machinery contain both the fundamental frequency and harmonics. The switch responds by shutting off the machine if any components of vibration exceed the set value.

The switch operates as follows:

- Mounted vertically on a vibrating machine, a steel ball is held by a permanent magnet into a conical seat
- If the vibration of the machine is sufficient to cause the ball to detach from the magnetic field of the magnet, it trips a latched lever, thus releasing a micro switch plunger so the machine can be stopped
- In type 3171MR, the ball and lever are latched by pressing the reset button manually
- In type 3171S, the ball and lever are latched by actuating a solenoid remotely, using an electrical signal or by pressing the reset button manually
- The SET LEVEL of the vibration switch is set by adjusting the gap between permanent magnet and ball.

Consult the FFE website at www.ffeuk.com for the latest information on applications and any new warnings that may affect installation or safety.

2. Warnings and Cautions

Read all Warnings and Cautions before Installation and Set-up.

2.1 Warnings

WARNING !	
	<ul style="list-style-type: none">• Risk of electric shock

- For electrical safety, the vibration switch must be earthed
- For your own safety, disconnect all electrical power to the vibrating machine and ensure the vibrating machine cannot operate during installation. Follow all safety warnings of the machine manufacturer
- For 3171S models, if the solenoid circuit is powered from a separate supply that is not automatically disconnected by the machine isolation device, then regulations require that the solenoid supply have its own isolation device and also must be identified both at the isolation device and vibration switch. The solenoid supply must be fused at a maximum of 5A.

2.2 Cautions

- To avoid corrosion inside the vibration switch keep enclosure sealed before and after installation
- The Cable Entry Cap is for transport and storage and is not suitable for resisting ingress of moisture if a vibration switch is installed in the field and not wired. Unless the switch is immediately wired using a suitable cable gland, replace the Cable Entry Cap with Blanking Plug 0051-002-01 (see accessories).

3. Mechanical Installation

3.1 Introduction

- Installation of the vibration switch shall only be carried out by qualified personnel
- Remove vibration switch from carton
- Vibration switch is factory set to 3 g, unless a preset switch has been ordered
- To reduce the risk of damaging internal components and wiring, installation and wiring must be performed within a temperature range of -10°C to +50°C
- Do not allow moisture or other airborne contaminants inside the switch as they can cause corrosion
- When closing the lid, ensure the seal is not lost or damaged.

The following tools will be needed:

- 3mm hexagon key for lid screws
- 4mm hexagon key to adjust SET LEVEL
- Wire strippers and wire cutters
- 3mm flat blade torque screwdriver for terminal block electrical connections
- 5mm flat blade torque screwdriver for internal protective earth terminal
- Adjustable spanner to fit cable gland

3.2 Mechanical Installation Details

The vibration switch must be fitted on the machine structure so that good transmission is ensured from the likely source of excess vibration.

The vibration switch shall be firmly fixed in the vertical orientation shown in figure 1 to a vertical surface of the vibrating machine using M5 fixings suitably resistant to vibration.

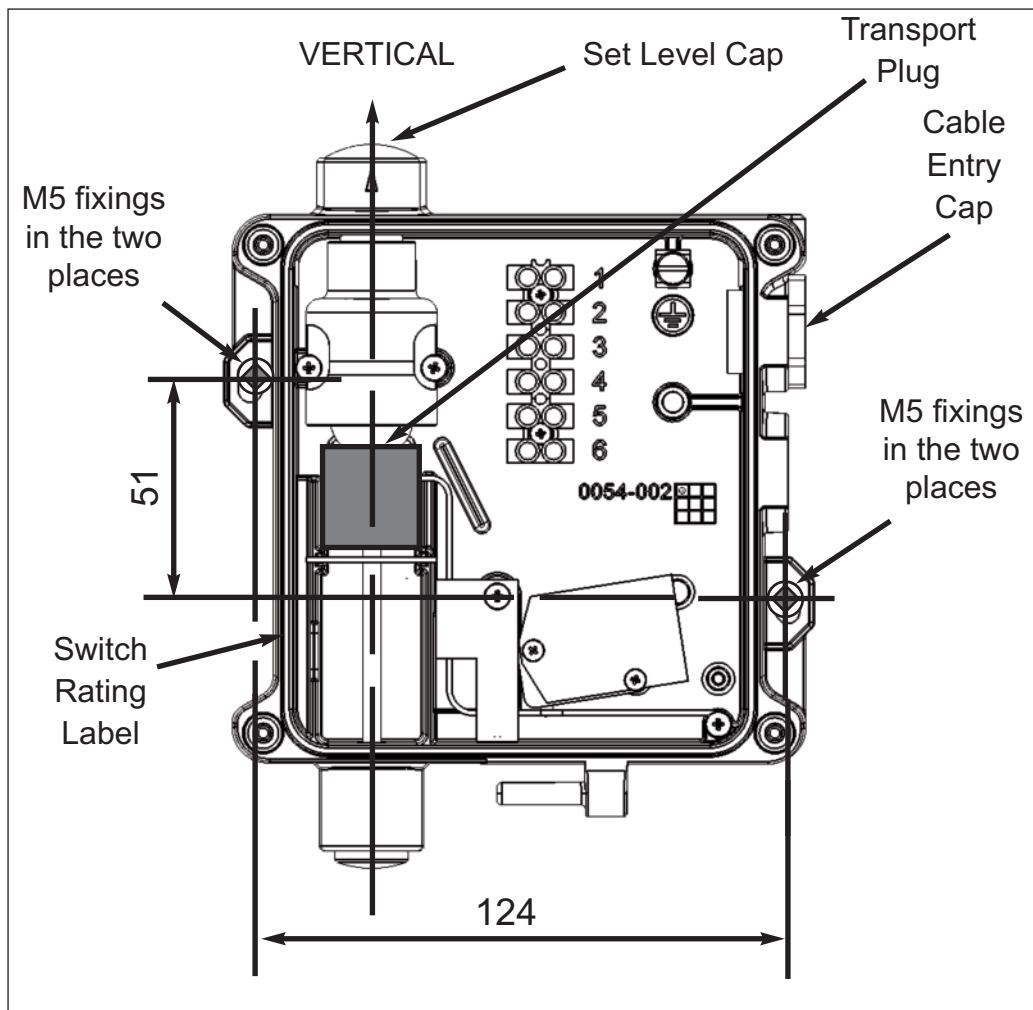

Figure 1: Mechanical installation to the surface of the vibrating machine

4. Electrical Installation

4.1 Introduction

- Do not exceed the switch contact ratings. The primary switching circuit is rated at 5 Amp maximum and must be fused appropriately in line with the protected machine's mains supply and isolation device
- The DC-operated solenoid has a duty cycle of 25%. It is advised that a time limiter or mono-stable device be fitted in line to automatically disconnect the solenoid supply after 30 seconds
- When connection is by a cord, the Earth wire connection must be longer than the Live and Neutral wires, such that failure of the strain relief will cause the Earth wire to be the last conductor interrupted
- To prevent water running down onto the vibration switch, add a 'drip loop' in any external cabling
- For ambient temperatures below -10°C , use external wiring rated for the minimum ambient temperature expected

4.2 Electrical Installation - Details

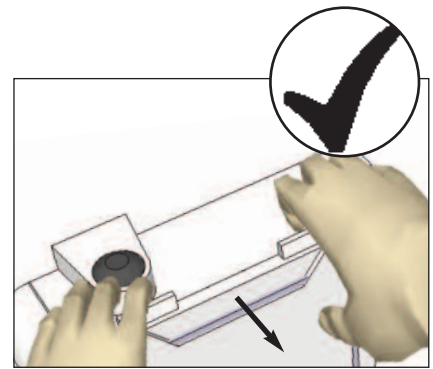
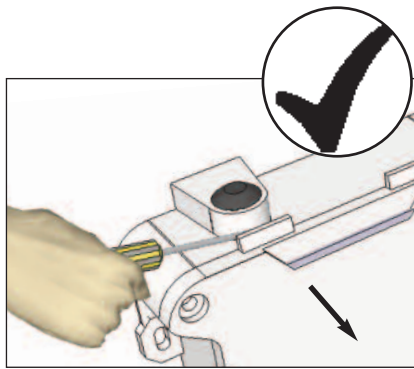
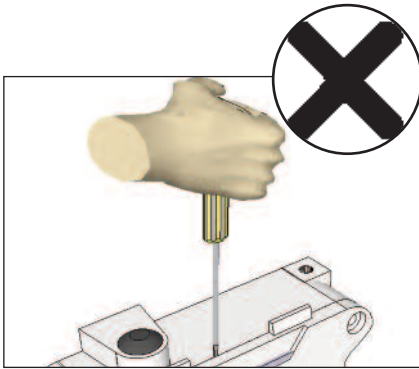
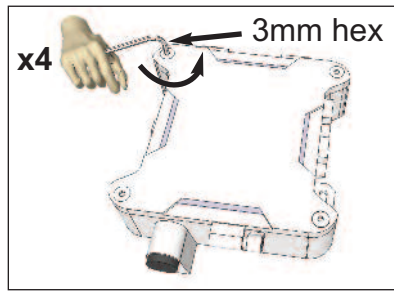

- To avoid breaking the lid hinge, DO NOT push on the lid when fully open.

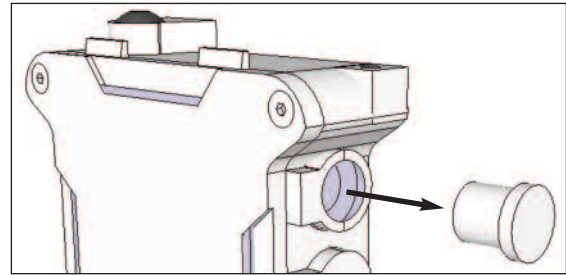
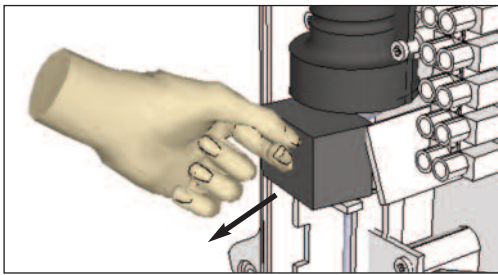
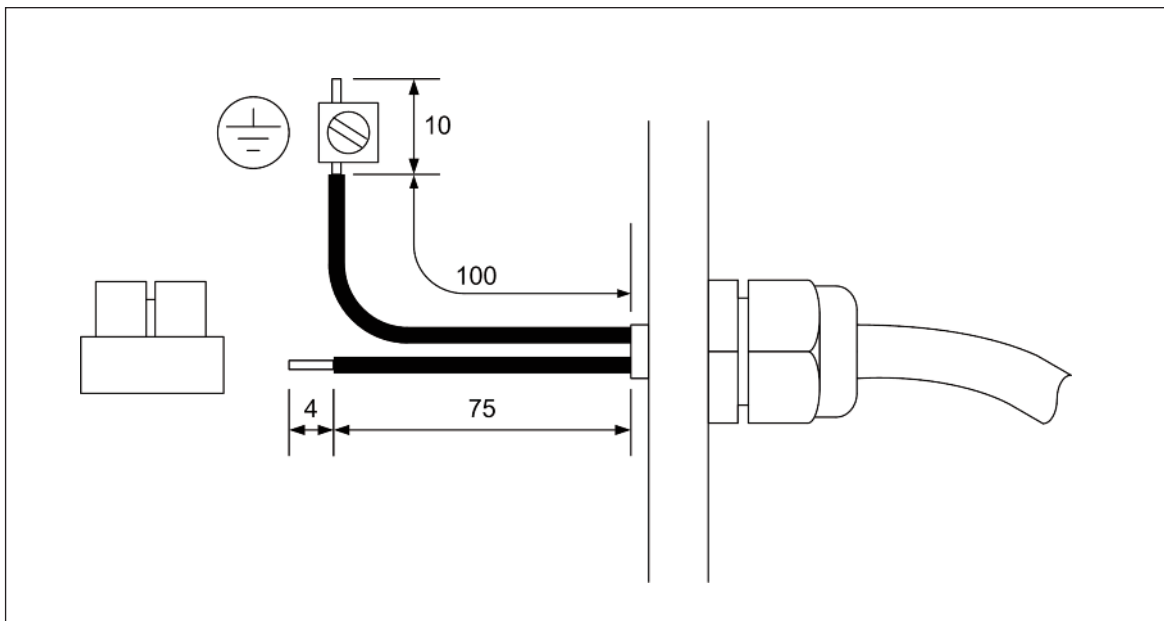

Figure 2: Before Installation



Tie-wrap wires to protect against vibration and using cable ties rated for expected ambient temperature.

Figure 3: Electrical Installation

Double-Throw Change-Over

Single Pole Change-Over

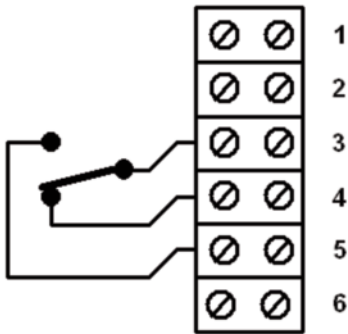

8000-000 / 8010-000

Double Pole Change-Over

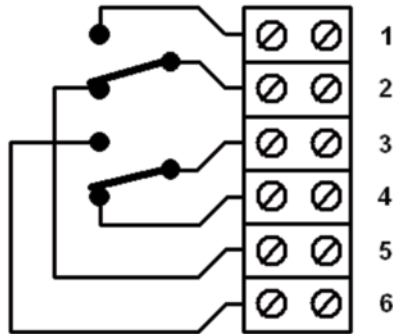

8001-000 / 8011-000

Single-Throw On-Off

Double Pole Normally Closed+Open

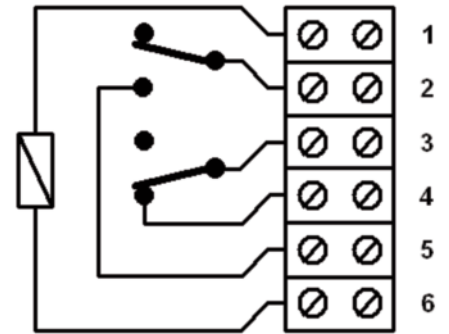

8001-010 / 8001-020 / 8001-030

Switches are shown in their reset state.

Figure 4: Wiring Configuration

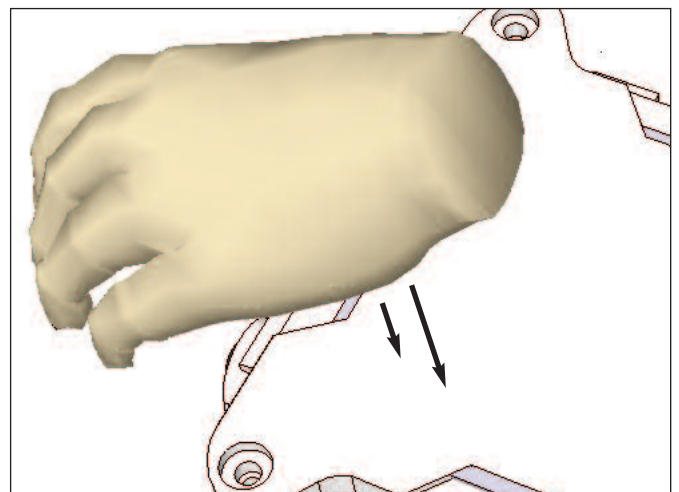
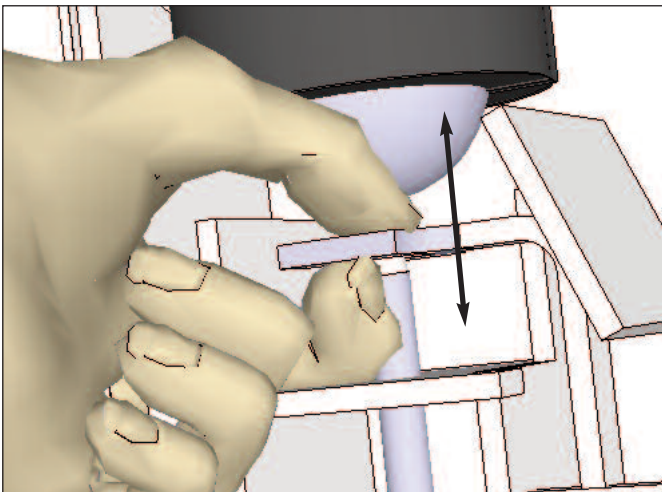

Check lever moves freely up and down.

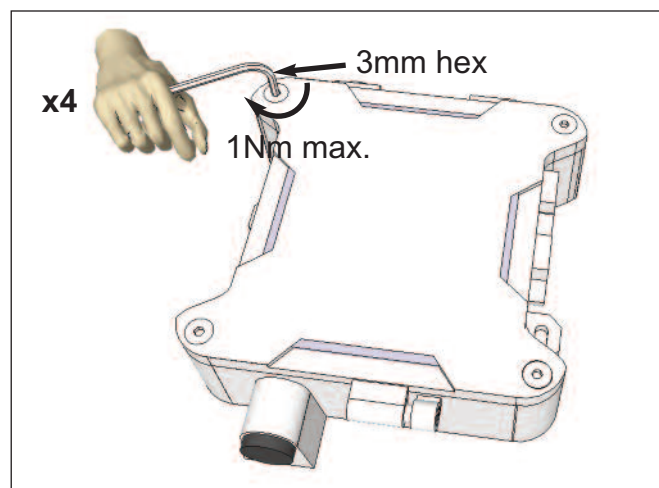
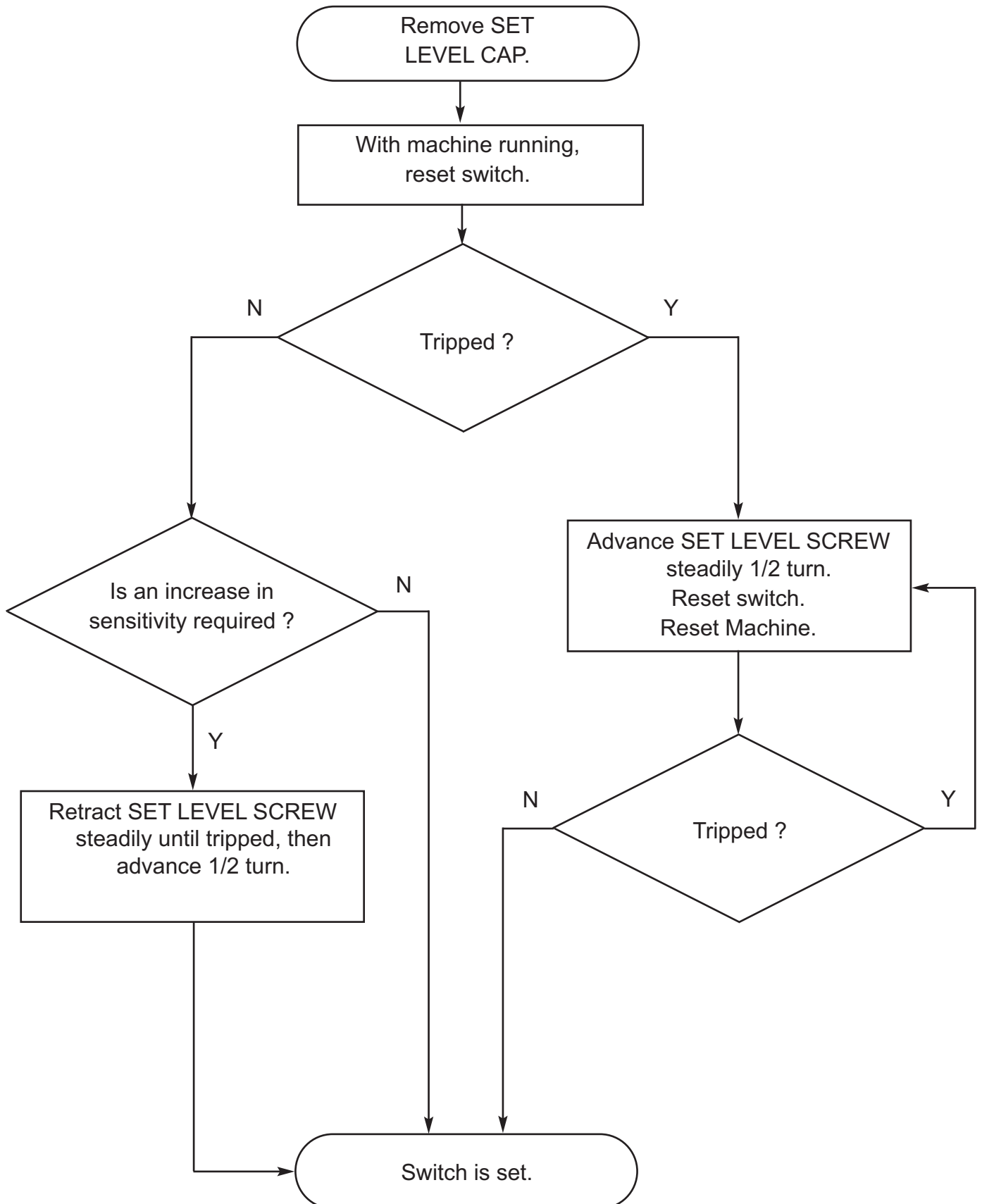

Figure 5

5. Set-up Sequence

No adjustment is needed if the vibration switch has been ordered preset for your application. Otherwise, the vibration switch is factory set accurately to 3g. For set up in the field, adjust SET LEVEL so that the switch no longer trips in normal running with reasonable sensitivity to excessive vibration as follows:



The SET LEVEL can be estimated by referring to the calibration curve in figure 6 and counting the number of turns from the factory setting.

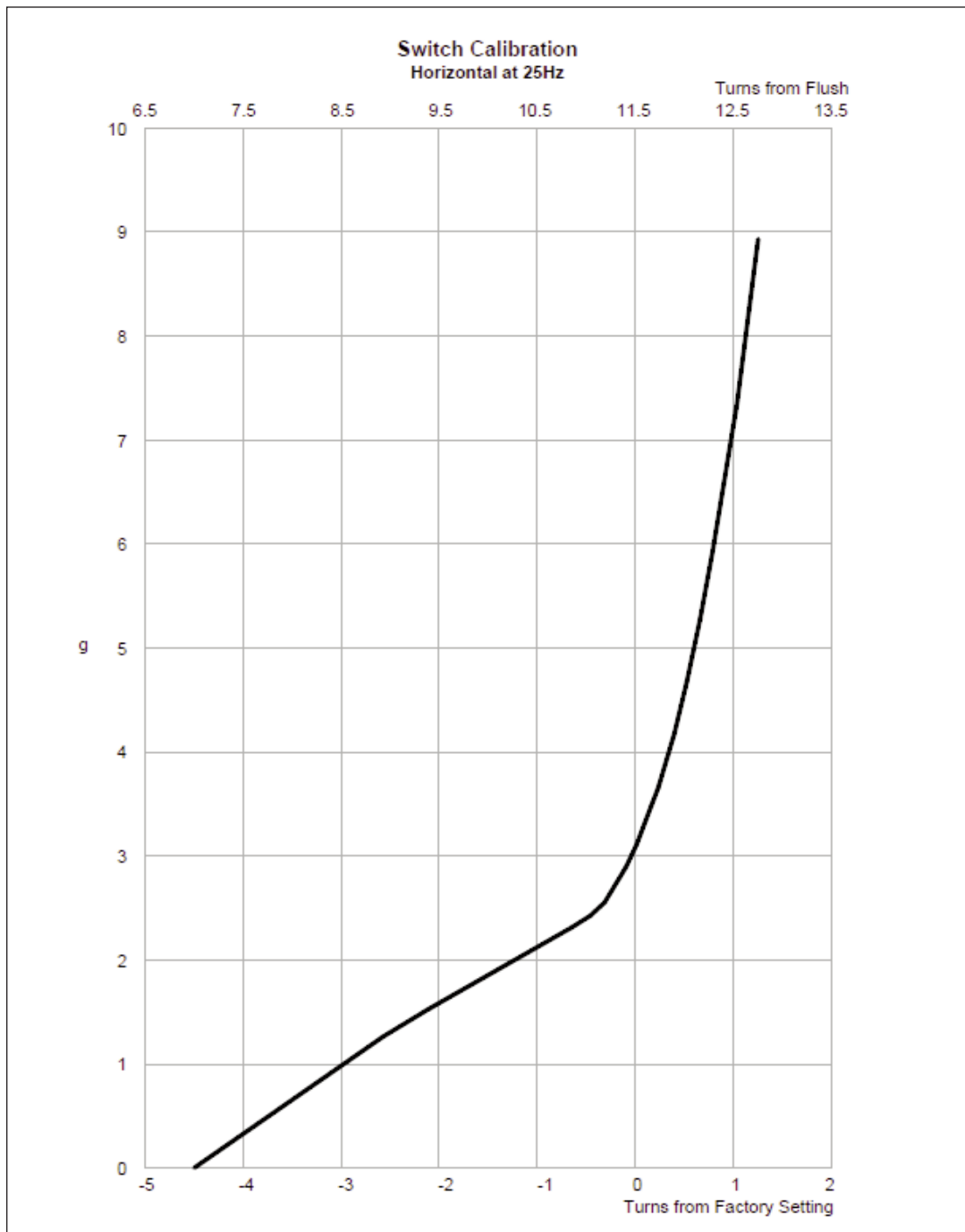
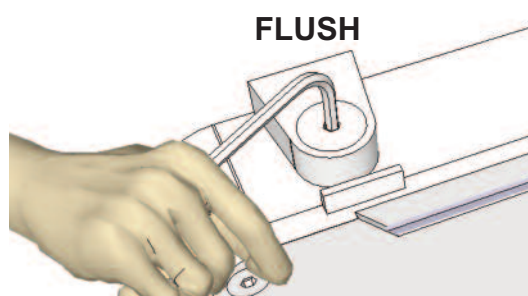

Figure 6: Vibration Switch Calibration Curve.

If the factory setting is lost, it can be approximated as 11.5 turns from flush.



6. Functional Test

To check correct set-up of the vibration switch, repeat set-up sequence section 5.

7. Maintenance

There are no user serviceable parts inside the vibration switch. Maintenance is not required except for periodic external visual inspection of the following:

- Confirm lid screws and vibration switch M5 fixings to machine are tight
- Confirm cable gland is tight to the enclosure and adequately secures the cable
- Confirm security of wires to external earth stud, where used
- Visually check vibration switch supply cable is installed as per local regulations and undamaged

8. Accessories

Part Number	Description	Picture
1000-026	LID ASSEMBLY - TYPE MR	
1000-028	LID ASSEMBLY - TYPE S	
G003	GLAND M20 TRS C I P	
S171	SEAL 400-024449041	
1000-027	4MM HEX DRIVER LONG	
0051-002-01	BLANKING PLUG IP66/67	
23640-083	ADAPTOR 20mm MALE	